

## TECHNISCHE DATEN • Technical Data • Dati tecnici • Caractéristiques Techniques

<b>Breite (Einbaumaß Korpus)</b> width (fitting measure body) larghezza largeur (dimension du corps de l'appareil)	<b>550 mm</b>	<b>Abgasmassenstrom</b> flue gas mass flow • flusso fumi • flux massique de gaz d'échappement	<b>7,5 g/s</b>
<b>Türrahmenhöhe</b> height doorframe • altezza antina • hauteur du cadre de porte	<b>510 / 570 / 680 mm</b>	<b>Abgastemperatur</b> flue gas temperature • temperatura fumi • température de gaz d'échappement	<b>330 °C</b>
<b>Türformen</b> door versione antina forme de la porte	<b>Ecke 90°</b> corner 90° angolo 90° angle 90°	<b>Mindestförderdruck</b> minimum feed pressure • depressione min. necessaria • pression de transport minimum	<b>14 Pa</b>
<b>Breite</b> width • larghezza • largeur	<b>579 mm</b>	<b>Umluftquerschnitt ohne / mit Nachheizfläche</b> throughput with / without heat exchanger • sezione di canalizzazione dell'aria calda convettiva con / senza rivestimento ad accumulo • section de la canalisation de l'air chaud avec / sans surface de restitution de chaleur	<b>700 / 1100 cm²</b>
<b>Tiefe</b> depth • profondità • profondeur	<b>579 mm</b>	<b>Dämmschichtdicken Promasil 950 KS (Boden / Seite / hinten / Decke*)</b> insulation thickness Promasil 950 KS (floor / sides / rear / ceiling*) • spessore isolante Promasil 950 KS - silicato di calcio (inferiore / laterale / posteriore / superiore*) • épaisseurs d'isolant Promasil 950 KS (sol / côté / arrière / en haut*)	<b>0 / 60 / 60 mm</b>
<b>Höhe</b> height • altezza • hauteur	<b>1230-1430 / 1290-1490 / 1400-1600 mm</b>	<b>Geschlossene Anlage möglich</b> closed construction possible • installazione ermetica possibile • installa- tion hermétique possible	<b>ja • yes • sì • oui</b>
<b>Gewicht</b> weight • peso • poids	<b>105 / 109 / 117 kg</b>	<b>Keramische Züge möglich</b> connection to ceramic flue heat exchangers possible • possibilità di con- vogliamento in scambiatore ceramico / refrattario • circulation d'air chaud dans canalisation céramique possible	<b>ja • yes • sì • oui</b>
<b>Nennwärmeleistung lt. EN</b> nominal heat output according to EN resa nominale secondo norme EN puissance de chauffage selon EN	<b>7 kW</b>	<b>Klapptüre</b> • hinged door • apertura a battente • porte ouverture latérale	
<b>Rauchrohrabgang</b> flue pipe outlet • diametro uscita fumi • sortie de tuyau de fumées	<b>Ø 180 mm</b>		

\* laut landesüblicher Installationsnormen • specification concerning fire prevention and thermal insulation •  
in ottemperanza con le normative locali vigenti • selon les normes d'installation régionales en vigueur

510

570

680

gerade  
flat / diritta / droit



## 510

## 570

## 680

Maßstab 1:40

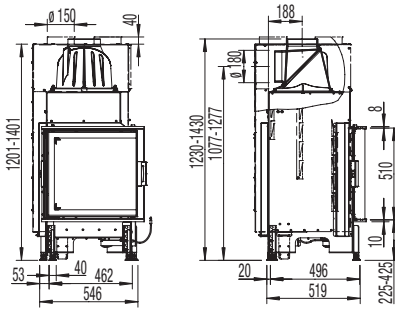

Maßstab 1:40

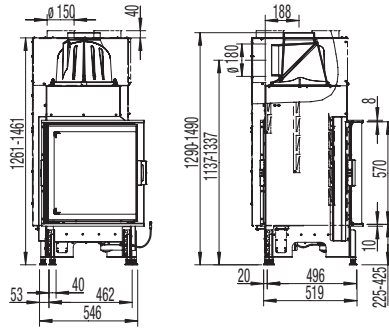

Maßstab 1:40

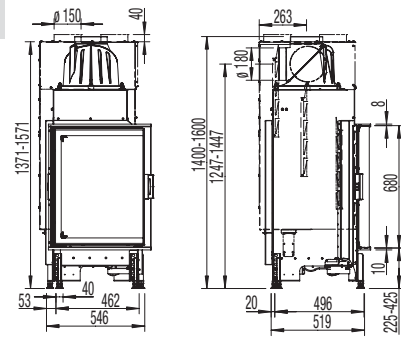

Maßstab 1:20

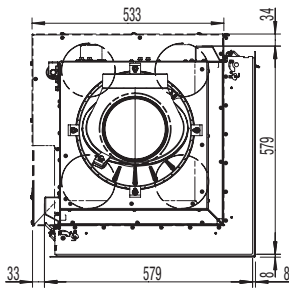

Maßstab 1:20

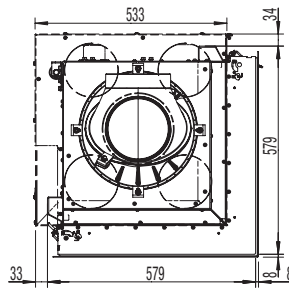

Maßstab 1:20

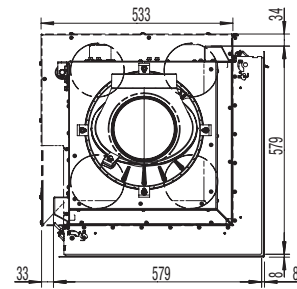

Maßstab 1:20

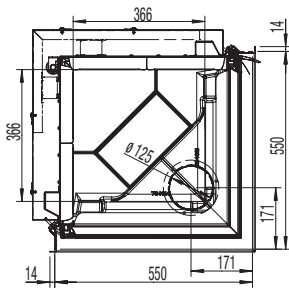

Maßstab 1:20

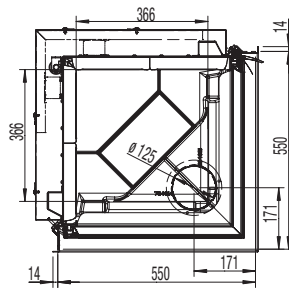

Maßstab 1:20

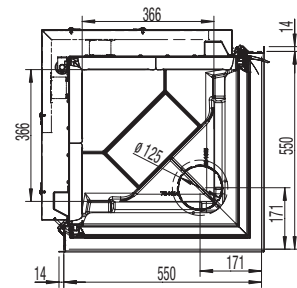

gerade  
flut / diritta / droit